

# KMC-41

## SERVICE MANUAL



## SPECIFICATIONS

### Microphone

Impedance..... 2.2k $\wedge$  (MAX)  
Sensitivity .....-65dB $\pm$ 4dB at 1kHz

### Speaker

Impedance.....16 $\wedge$  $\pm$ 15% at 1kHz  
Rating input .....0.5W  
Maximum input .....1.5W  
Dimensions (W x H x D) ..... 67.8 x 91.5 x 43.3 mm (2-21/32 x 3-9/16 x 1-23/32 inches)  
Weight..... Approx. 260g/9.2oz

EPCOM syscom – 1630 Paisano Dr. – El Paso. Tx 79901. Ph (915)533-5119 – [www.epcom.net](http://www.epcom.net)



## DISASSEMBLY FOR REPAIR

### 1. Removing the cable ASSY

- 1) Pull out the holder that is set into the fixing bracket of the cable ASSY, using a pair of pliers.

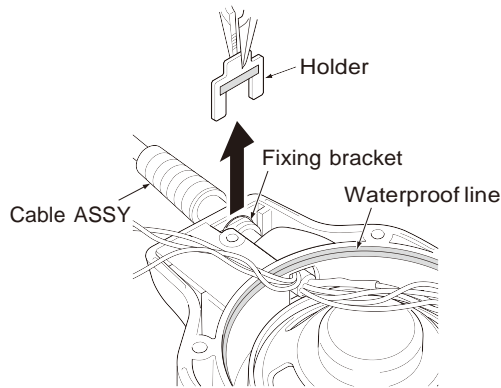

Fig. 1

- 2) Completely peel off the bond (\*1) glued to the cable ASSY, using a set of nippers.
 

**Note:** Please be careful not to damage the coating of the cable ASSY and the waterproofing line of the front case.

\*1: Use the following bond:

- Manufacture name: Shin-Etsu Chemical Co., Ltd.
- Bond name: Shin-Etsu silicone One-component RTV silicone rubbers Alcohol type KE-4898-T

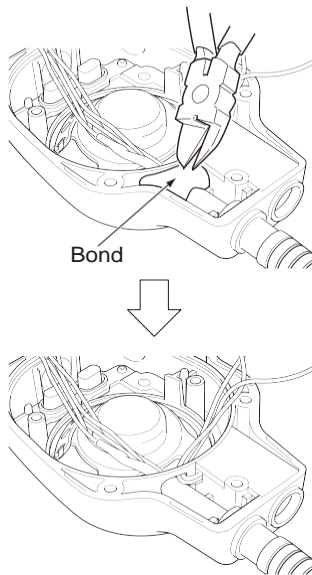

Fig. 2

- 3) Following the procedure below, pass through the connector part of the cable ASSY into the hole of the front case (waterproof line part).

- (1) Move the three lead wires soldered onto the PCB to the upper corner of the hole.
- (2) The yellow lead wire side of the connector comes in the inside of the front case.

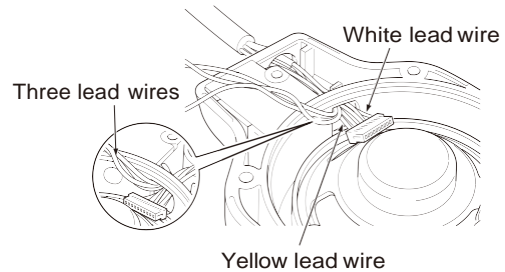

Fig. 3

- (3) Push the cable ASSY to the earphone jack side with the connector part bent as shown in the figure, then hook the end of the connector (white lead wire side) into the outside corner of the hole, using your finger.
- (4) Pass the connector through the hole, pushing the connector (yellow lead wire side) using a pair of tweezers or similar tool.

**Note:** Attach adhesive tape or rubber to the end of the tweezers so as not to damage the connector of the cable ASSY.

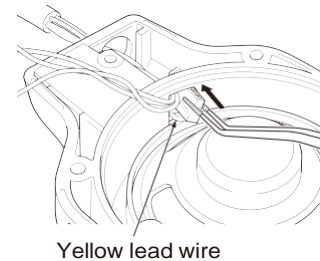

Fig. 4

- 4) Pull the cable ASSY, then remove the cable ASSY from the front case by passing the connector part through the hole of the front case.

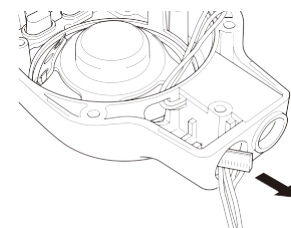

Fig. 5

## DISASSEMBLY FOR REPAIR

### 2. Installing the cable ASSY

- 1) Pass the connector part of cable ASSY through the hole of the front case.
- 2) Move the three lead wires soldered onto the PCB to the upper corner of the hole.

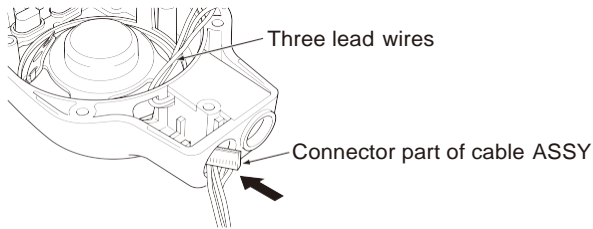

Fig. 6

- 3) Make sure the yellow lead wire side of the connector is in the inside of the front case.

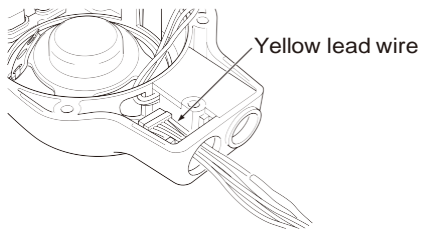

Fig. 7

- 4) Push the connector (yellow lead wire side) to the lower corner of the hole using a pair of tweezers.

**Note:** Attach adhesive tape or rubber to the end of the tweezers so as not to damage the connector of the cable ASSY.

- 5) Pass the connector through the hole by pushing the connector (white lead wire side) using a pair of tweezers or similar tool.

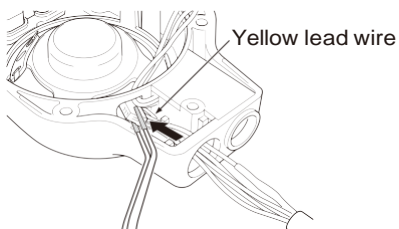

Fig. 8

- 6) Push the cable ASSY to the inside of the case, then insert the fixing bracket of the cable ASSY to the hole of the front case.
- 7) Fit the holder to the fixing bracket of the cable ASSY.

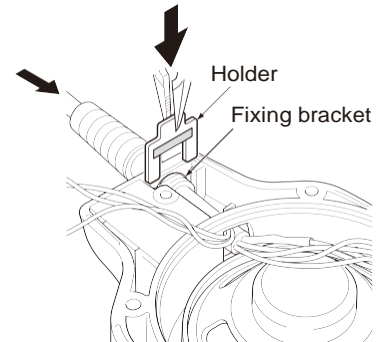

Fig. 9

- 8) Insert the cap in the earphone jack hole of the front case.
- 9) Apply the bond (\*1) at the position shown in the figure, then firmly attach the cable ASSY and case.

**Note:** Take care not to apply the bond to the waterproofing line of the front case.

\*1: Use the following bond :

- Manufacture name: Shin-Etsu Chemical Co., Ltd.
- Bond name: Shin-Etsu silicone One-component RTV silicone rubbers Alcohol type KE-4898-T

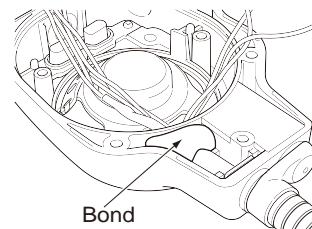
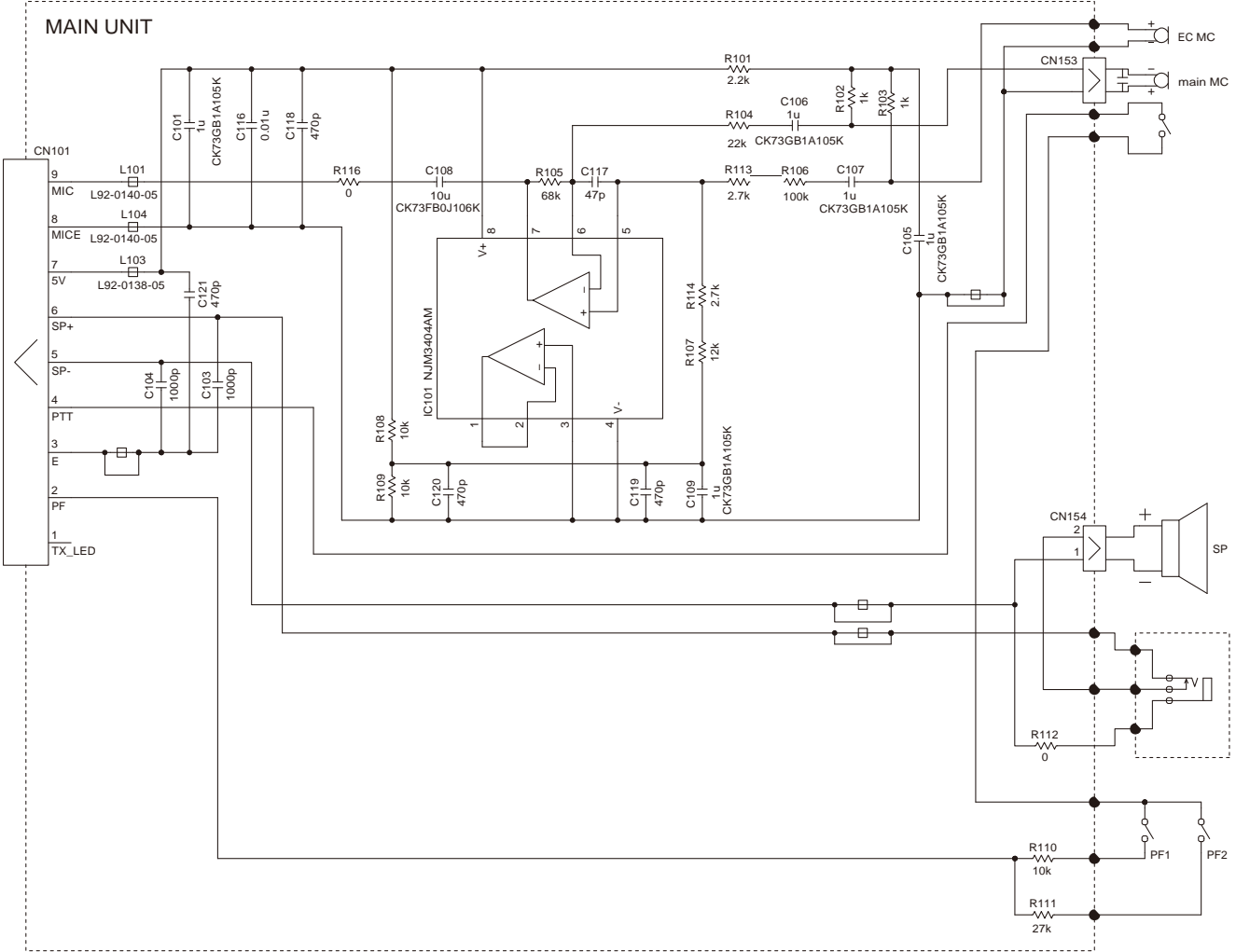
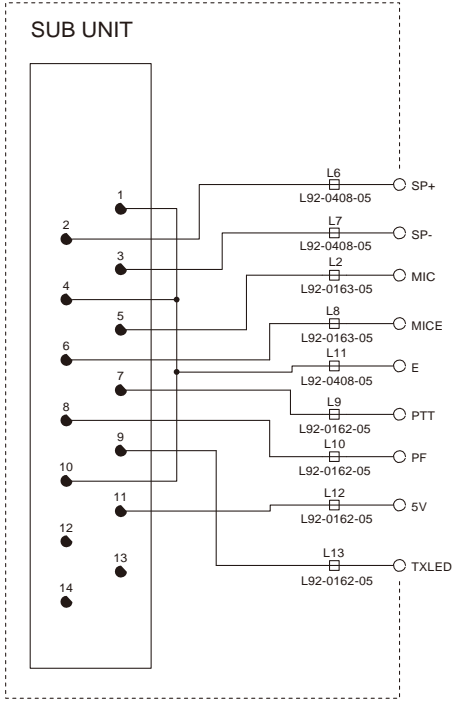

Fig. 10



**SCHEMATIC DIAGRAM**



## PARTS LIST

### KMC-41 (Y58-4000-20)

Ref. No.	Address	New parts	Parts No.	Description	Destination
<b>KMC-41</b>					
1		*	A02-4050-08	PLASTIC CABINET ASSY	
2		*	A82-0073-08	REAR PANEL	
4		*	B43-1616-08	BADGE (KENWOOD)	
5		*	B43-1618-08	BADGE (KMC-41)	
7		*	D10-0654-08	LEVER (PTT)	
9		*	E11-0712-08	3.5D PHONE JACK	
10		*	E30-7657-08	CURL CABLE ASSY	
12		*	G10-1358-08	FIBROUS SHEET	
13		*	G10-1386-08	FIBROUS SHEET (PHONE JACK)	
14		*	G11-4450-08	SHEET (LEAK TEST)	
15		*	G11-4452-08	SHEET (PHONE JACK)	
16		*	G13-2241-08	CUSHION (PTT)	
17		*	G53-1779-08	PACKING (PTT)	
18		*	G53-1784-08	PACKING (BOTTOM CAP)	
20		*	J19-5515-08	HOLDER (PTT)	
21		*	J26-2003-08	PRINTED WIRING BOARD ASSY	
22		*	J29-0740-08	BELT HOOK ASSY	
23		*	J99-0729-08	ADHESIVE SHEET (JACK COVER)	
A		*	N08-0566-08	DRESSED SCREW (UNIVERSAL)	
25			S70-0471-08	TACT SWITCH (PF)	
26		*	S70-0511-08	TACT SWITCH (PTT)	
28			T07-0359-18	SPEAKER	
29			T91-0584-08	MIC ELEMENT (MAIN MIC)	
30		*	T91-0660-08	MIC ELEMENT (SUB MIC)	

**EPCOM syscom** – 1630 Paisano Dr. – El Paso. Tx 79901. Ph (915)533-5119 – [www.epcom.net](http://www.epcom.net)

## Kenwood Corporation

2967-3, Ishikawa-machi, Hachioji-shi, Tokyo, 192-8525 Japan

### Kenwood U.S.A. Corporation

P.O. BOX 22745, 2201 East Dominguez Street, Long Beach, CA 90801-5745, U.S.A.

### Kenwood Electronics Canada Inc.

6070 Kestrel Road, Mississauga, Ontario, Canada L5T 1S8

### Kenwood Electronics Deutschland GmbH

Rembrücker Str. 15, 63150 Heusenstamm, Germany

### Kenwood Electronics Belgium N.V.

Leuvensesteenweg 248 J, 1800 Vilvoorde, Belgium

### Kenwood Electronics France S.A.

L'Etoile Paris Nord 2, 50 Allée des Impressionnistes, Bp 58416 Villepinte, 95944 Roissy Ch De Gaulle Cedex

### Kenwood Electronics UK Limited

KENWOOD House, Dwight Road, Watford, Herts., WD18 9EB United Kingdom

### Kenwood Electronics Europe B.V.

Amsterdamseweg 37, 1422 AC Uithoorn, The Netherlands

### Kenwood Electronics Italia S.p.A.

Via G. Sirtori, 7/9 20129 Milano, Italy

### Kenwood Ibérica, S.A.

Bolivia, 239-08020 Barcelona, Spain

### Kenwood Electronics Australia Pty. Ltd.

(A.C.N. 001 499 074)

16 Giffnock Avenue, Centrecourt Estate, North Ryde, N.S.W. 2113 Australia

### Kenwood Electronics (Hong Kong) Ltd.

Unit 3712-3724, Level 37, Tower one Metroplaza, 223 Hing Fong Road, Kwai Fong, N.T., Hong Kong

### Kenwood Electronics Singapore Pte Ltd

1 Ang Mo Kio Street 63, Singapore 569110

