

158EZDM



7-16 DIN Male EZfit® for 1-5/8 in FXL-1873 and AVA7-50 cable

Product Classification

Product Type	Wireless and radiating connector
Product Brand	EZfit®
Product Series	AVA7-50 AVA7RK-50
Ordering Note	CommScope® non-standard product

General Specifications

Body Style	Straight
Inner Contact Attachment Method	Captivated
Inner Contact Plating	Silver
Interface	7-16 DIN Male
Mounting Angle	Straight
Outer Contact Attachment Method	Clamp
Outer Contact Plating	Trimetal
Pressurizable	No

Dimensions

Length	71.63 mm 2.82 in
Diameter	62.99 mm 2.48 in
Nominal Size	1-5/8 in

Outline Drawing

158EZDM

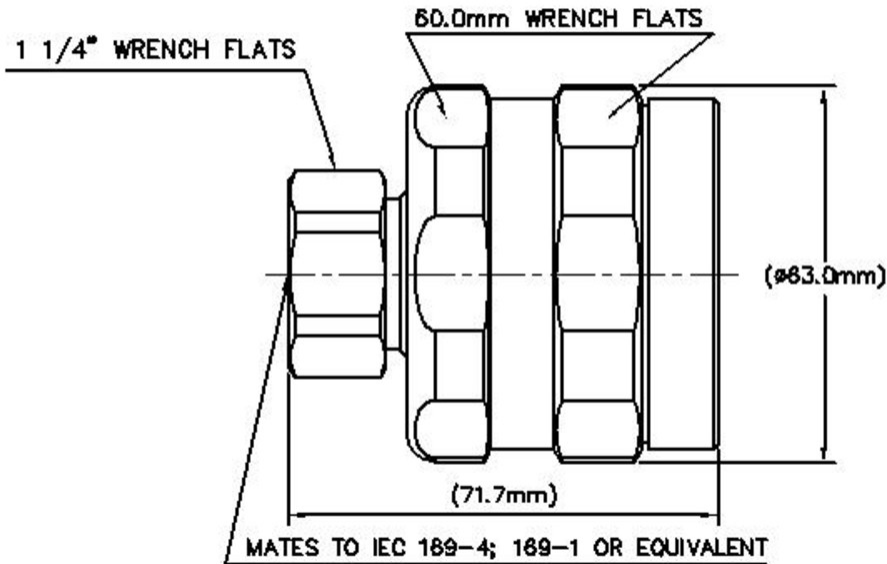

Electrical Specifications

3rd Order IMD at Frequency	-116 dBm @ 1800 MHz
3rd Order IMD Test Method	Two +43 dBm carriers
Insertion Loss, typical	0.05 dB
Average Power at Frequency	3.0 kW @ 900 MHz
Cable Impedance	50 ohm
Connector Impedance	50 ohm
dc Test Voltage	4000 V
Inner Contact Resistance, maximum	1.5 mOhm
Insulation Resistance, minimum	5000 MOhm
Operating Frequency Band	0 – 2700 MHz
Outer Contact Resistance, maximum	0.8 mOhm
Peak Power, maximum	40 kW
RF Operating Voltage, maximum (vrms)	1415 V
Shielding Effectiveness	-130 dB

VSWR/Return Loss

Frequency Band	VSWR	Return Loss (dB)
45–400 MHz	1.02	41.7

158EZDM

401–805 MHz	1.03	37
806–960 MHz	1.04	34.6
961–1709 MHz	1.04	34.16
1710–2170 MHz	1.05	33.1
2170–2399 MHz	1.05	33.1
2400–2700 MHz	1.05	32.26

Mechanical Specifications

Attachment Durability	25 cycles
Connector Retention Tensile Force	2,224.11 N 500 lbf
Connector Retention Torque	13.56 N-m 119.998 in lb
Coupling Nut Proof Torque	24.86 N-m 220.003 in lb
Coupling Nut Retention Force	1,000.85 N 225 lbf
Coupling Nut Retention Force Method	MIL-C-39012C-3.25, 4.6.22
Insertion Force	200.17 N 45 lbf
Insertion Force Method	IEC 61169-1:15.2.4
Interface Durability	500 cycles
Interface Durability Method	IEC 61169-4:9.5
Mechanical Shock Test Method	MIL-STD-202F, Method 213B, Test Condition C

Environmental Specifications

Operating Temperature	-40 °C to +85 °C (-40 °F to +185 °F)
Storage Temperature	-55 °C to +85 °C (-67 °F to +185 °F)
Attenuation, Ambient Temperature	20 °C 68 °F
Average Power, Ambient Temperature	40 °C 104 °F
Corrosion Test Method	MIL-STD-1344A, Method 1001.1, Test Condition A
Immersion Depth	1 m
Immersion Test Mating	Mated
Immersion Test Method	IEC 60529:2001, IP68
Moisture Resistance Test Method	MIL-STD-202F, Method 106F
Vibration Test Method	IEC 60068-2-6
Water Jetting Test Mating	Mated
Water Jetting Test Method	IEC 60529:2001, IP66

158EZDM

Packaging and Weights

Weight, net 563.6 g | 1.243 lb

Regulatory Compliance/Certifications

Agency	Classification
CHINA-ROHS	Below maximum concentration value
ISO 9001:2015	Designed, manufactured and/or distributed under this quality management system
REACH-SVHC	Compliant as per SVHC revision on www.commscope.com/ProductCompliance
ROHS	Compliant



* Footnotes

Insertion Loss, typical	0.05v̄freq (GHz) (not applicable for elliptical waveguide)
Immersion Depth	Immersion at specified depth for 24 hours